



**DCC Uncoupler
Conversion Kit
O scale**

Installation Manual

(en)

Table of Contents

1. KIT CONTENTS.....	2
2. INTRODUCTION.....	2
3. MECHANICAL INSTALLATION.....	3
3.1. Find the right mounting position.....	3
3.2. Attach the actuator.....	3
3.3. Attach the thread.....	3
4. ELECTRICAL INSTALLATION.....	4
4.1. DCC Decoder Requirements.....	4
4.2. Wiring.....	4
4.3. Both couplers on one function output (Option 1).....	5
4.4. Two independent operated couplers (Option 2).....	5
4.5. Using a standard low-power function output.....	6
4.6. Using a TTL function output.....	7
5. PROGRAMMING THE DECODER.....	8
5.1. General considerations.....	8
5.2. Operation with a standard DCC decoder (without "uncoupling macro" function).....	8
5.3. Operation with ZIMO Decoders (MX634 and similar).....	8
5.4. Operation with ESU Lokpilot 4.0.....	9
6. SPECIFICATIONS.....	10
7. TROUBLESHOOTING.....	10
8. APPENDIX.....	11
8.1. Warranty.....	11
8.2. Contact.....	11
8.3. About this document.....	11

1. KIT CONTENTS

- 2 micro actuators (5/64" x 15/32" / 6 x 12mm) with reel head
- 2 series resistors
- 3 ft./1m of special strong and thin black thread
- 1 pc. of shrink hose
- Comprehensive installation instructions

2. INTRODUCTION

The DCC Uncoupler Conversion Kit has been designed to add remote uncoupling via DCC control to your rolling stock. It gives you the freedom to uncouple wherever you wish to, at any position on your layout - independent from fixed magnets! The kit is meant to be used with your existing couplers. It's a simple addition and requires very few modifications on your rolling stock, most of them can be even be undone without leaving any traces.

Uncoupling works by pulling the knuckle of the coupler via a thin thread, powered by a tiny actuator (motor) rolling up the thread. The thread is simply looped around the knuckle, while the actuator is positioned e.g. behind the coupler box.

Most DCC decoders can be used to drive the actuators, it requires only one function output for both couplers.

3. MECHANICAL INSTALLATION

Thanks to their size, the actuators can be installed in a variety of places under or in your loco. This chapter helps you to find the optimal place for the actuators.

3.1. Find the right mounting position

The actuators might be placed below or behind the coupler's gearbox, or attached elsewhere to the body of the loco. For best results, please ensure the following:



- **Whenever possible, run the thread from the knuckle to the actuator in free air. Do not route it over corners as this will hinder proper operation!**
- **Make sure the thread path from knuckle towards the actuator runs parallel with the shank of the coupler. This ensures that the coupler stays centered while the knuckle is opened. Preferred installation is behind (if possible) or underneath the coupler's gearbox.**

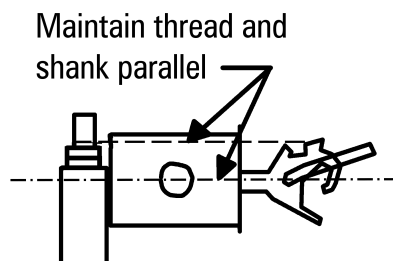

3.2. Attach the actuator



For a test drive, it is recommended to attach the actuator with double-sided adhesive tape.

When satisfied, remove the tape and glue the actuator on its place hotmelt or gemstone glue ("GEM-TAC" or "Jewel-It"). The latter has the advantage that it remains somewhat flexible, and that it can be removed using alcohol if required.

- Remove any dirt and grease from both the actuator and the mounting surface using alcohol.
- Make sure that no glue drips onto the reel and on the front part of the actuator.

3.3. Attach the thread

For best results, please follow the exact order below:

1. Prepare the coupler's knuckle: For the attachment of the thread, a small groove needs to be filed in the into the knuckle. The groove should be deep enough that the thread with some glue can be inserted without overlapping of the knuckle's profile.

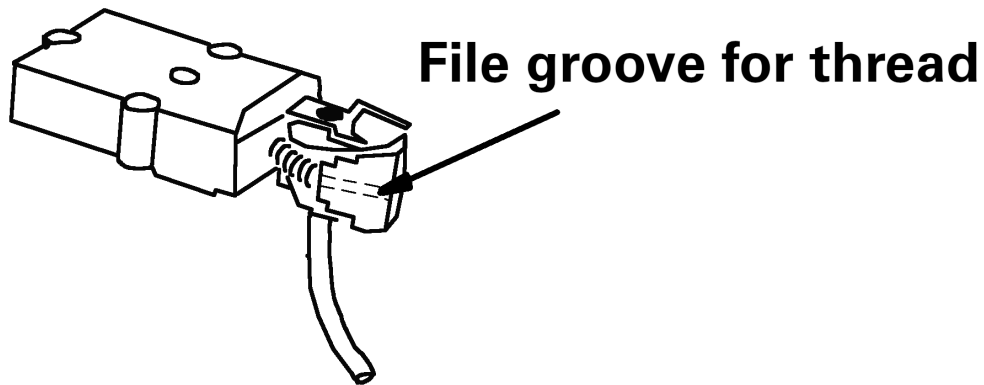

2. Attach the thread to the coupler's knuckle: Carefully place the thread into the groove and fix it with a tiny drop of super-glue. Hint: This is best achieved by picking up a small amount of glue with a toothpick and dropping it directly over the knot. Cut off the overlapping end of the thread and remove any excess glue from the knuckle. **The knuckle must now have exactly the same profile as before when looking from top; any residues will hinder coupling!**
3. Pull the thread to the actuator's reel, make one winding around the reel and make a single knot.
4. Adjust the length of the thread by pulling on it at either side of the reel. The length is ideal when the thread is semi-tight while the coupler is swung to its outermost (right) position.



1. If you're satisfied with the length, fix the thread on the reel using a tiny (!) drop of super-glue. Be careful not to bring any glue into the gap between the reel and the actuator. Hint: This is best achieved by picking up a small amount of glue with a toothpick and dropping it directly over the knot. Using too much will likely creep into the gap between the actuator, or it might creep along the thread and harden it.



The reel is clamped on the axle through spring pressure and can be removed and re-attached on the actuator's axle as required.

4. ELECTRICAL INSTALLATION

4.1. DCC Decoder Requirements

You will need a DCC decoder with one (for simultaneous operation of both couplers) or two (for independent operation) free function output(s), each capable of supplying **at least 150mA of current**.

Please consult your decoder's documentation about the current limit on the function output. If it does not source enough current, the couplers can still be used but a little extra electronic is required (see section 4.5 and 4.6)

See chapter 5. "Programming the Decoder" for more information.

4.2. Wiring

Wiring should be done accordingly to the desired operation (see below). Use the supplied extension cables as required and make sure you isolate the solder joints using shrink hose to avoid short circuits.



The resistors are designed for short-term operation only. They can get hot during coupler operation, so make sure it does not touch any plastic parts. The resistor's body should only be in contact with metal surfaces, or alternatively with enough air gap around it. You could also put some thermal paste on the resistors to ensure better heatsinking towards the metal parts of the loco's body.



The actuator's sense of rotation can be reversed by changing its polarity. Depending on your mounting situation, one direction may work better than the other, so it is advisable to try both before making the wiring permanent.

4.3. Both couplers on one function output (Option 1)

This is recommended for most locomotives because it doesn't matter when the front coupler is also actuated while decoupling at the rear, and vice versa. Many standard decoders have one free function output (when using a standard 8-pin interface, this output is usually the green wire on Pin 3).

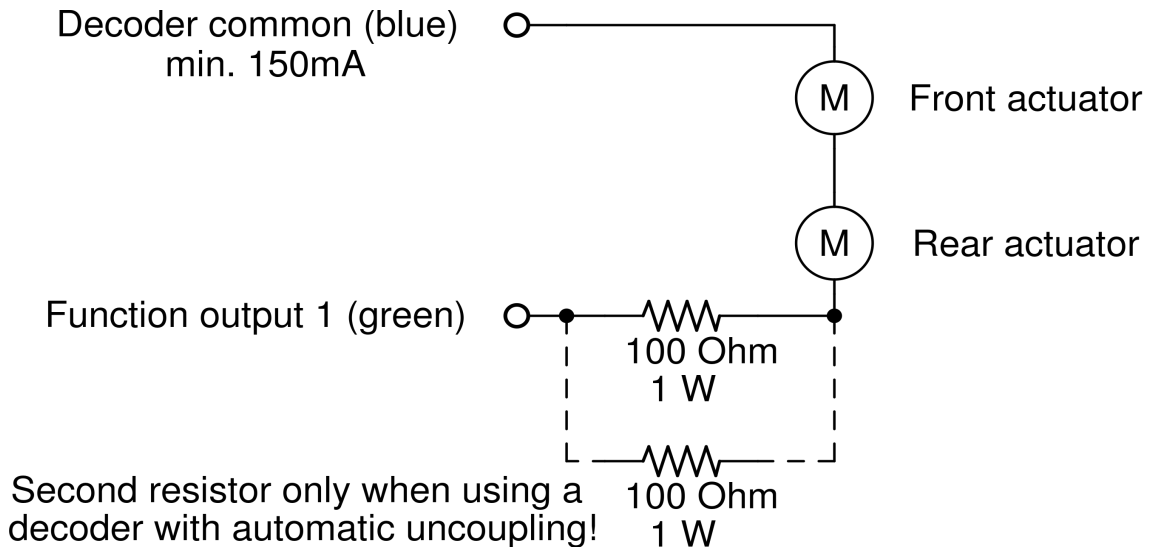

The second (paralleled) resistor has the effect that more current (250mA) is flowing through the actuators. This improves uncoupling of a single car because the opening coupler has an "kick-off" effect. Use ONLY with a properly timed decoder (ZIMO, ESU) with automatic uncoupling function, otherwise you will burn the actuators very quickly! The output must be able to supply 250 mA for a short duration.

4.4. Two independent operated couplers (Option 2)

This method is preferred if you want to install the mod kit within cars. By their nature, cars are often coupled at both ends, and having the couplers controlled independently is required to decide where decoupling from the rest of the train should happen. Note: This option requires two function outputs on the DCC controller.

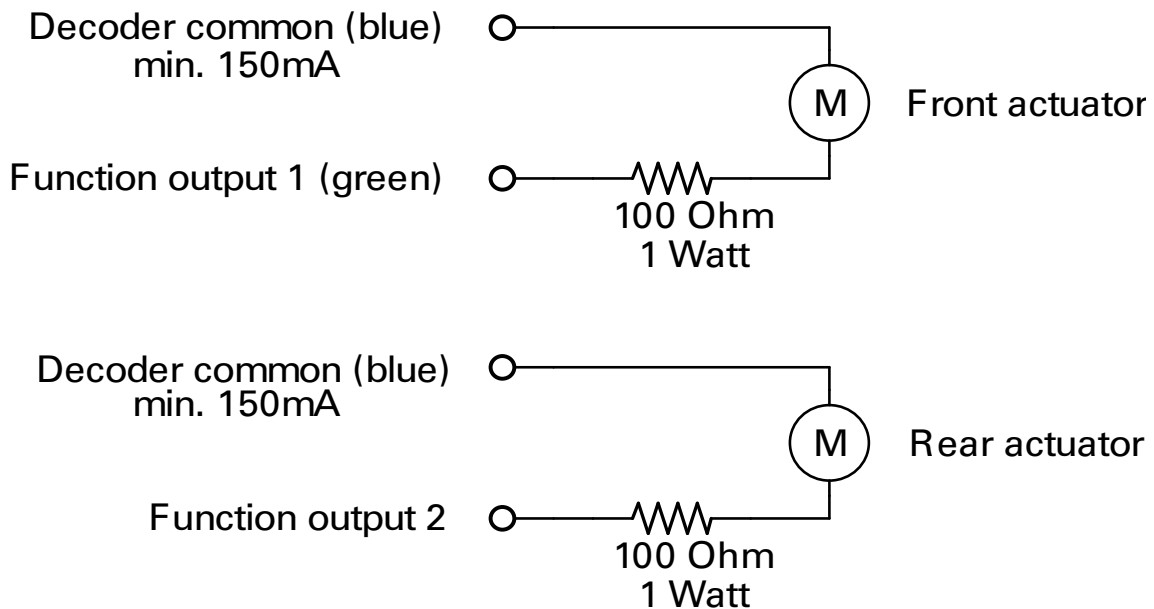

4.5. Using a standard low-power function output

If the decoder has no outputs available which can source the required 150mA, you can use the following circuit to amplify the decoder's output to the required strength:

NOTE: Decoder GND is not found on the 8-pin connector, but is available on every decoder (often exposed on a separate solder pad).

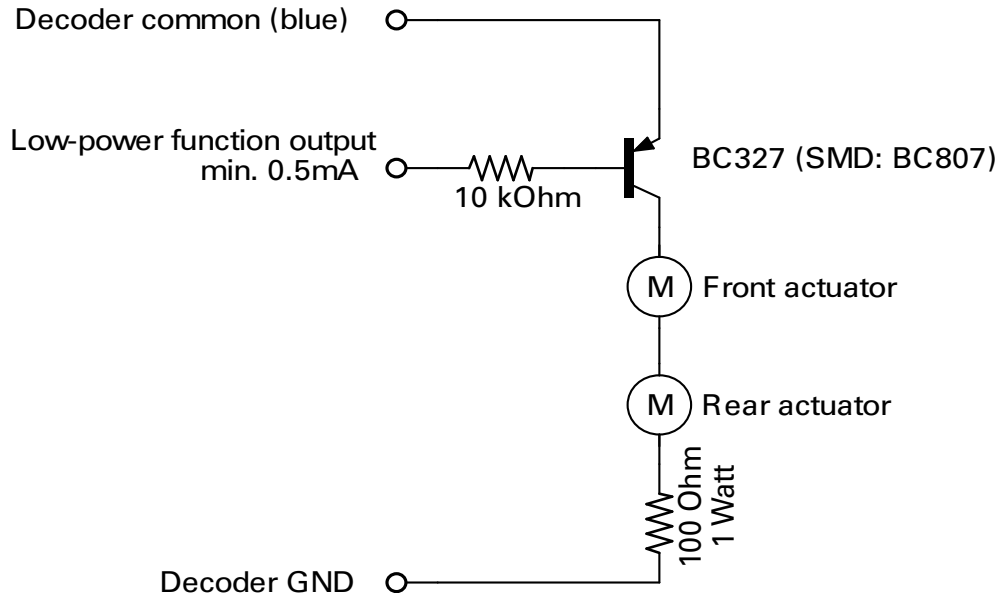

4.6. Using a TTL function output

Some decoders (like ESU Lokpilot) have TTL outputs. They can also be used with an appropriate circuit:

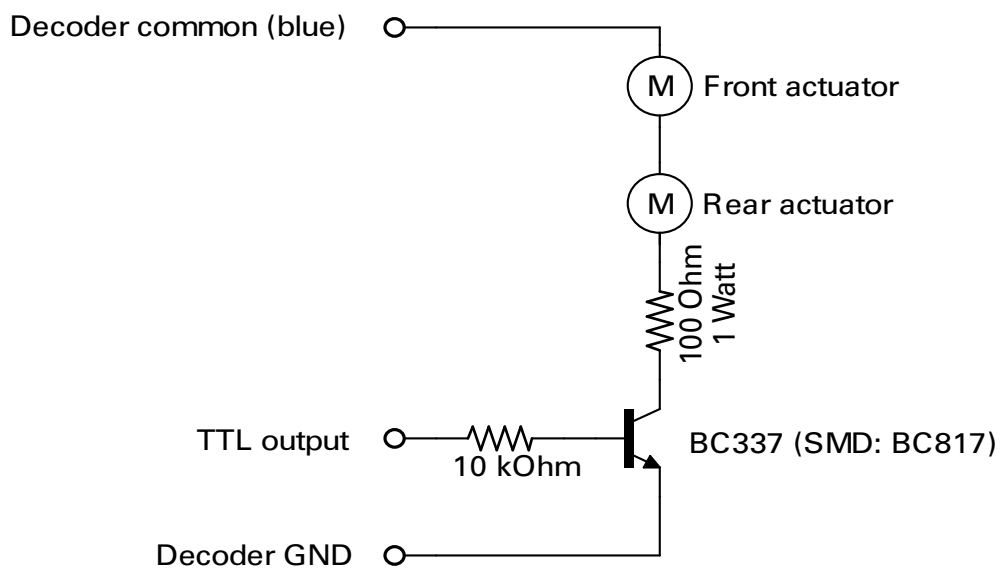

5. PROGRAMMING THE DECODER

5.1. General considerations

Although not required, a decoder with integrated "digital coupler" function (aka "uncoupling macro") is helpful because it makes the entire uncoupling process a one-touch operation.

The sequence for uncoupling is:

Back up → open knuckle → back away → release knuckle

Decoders with "digital coupler" function can execute this sequence on a single function key press. To configure the decoder accordingly, please consult your decoder's manual of how to set up the "digital coupler" function. (Note: ESU Lokpilot 4.0 requires a special tweak, see below).

Alternatively, you need to choose to program your function output as "momentary" or "time-limited" on the decoder or on your command station and control movement by hand.

Don't use permanent "on/off" function for this as you might risk to burn the actuator if you forget to switch it off!



In any case, it is required that the decoder's output is time-limited in operation! The actuators (and the series resistors) are not designed for permanent operation and will overheat when continuously switched on for more than 5..10 seconds!

The resistor can get hot during normal operation, so make sure it does not touch any plastic parts. Install the resistor with free air around it, or touching only metal parts.



Correct timing is crucial for operation. The coupler must be actuated while it is in "push" position, but should have as less load as possible on it. This situation is given in the above sequence just when the loco has stopped after backing up (or just a slight hint before that). Try to play around with your decoder's timing parameters to find the optimal setting.

5.2. Operation with a standard DCC decoder (without "uncoupling macro" function)

- Wire the uncoupler according to the desired schematic to the function output / common wire of your DCC decoder. Please refer to the decoder's manual to find the proper pins/connections.
- Program the decoder in a way that the function output acts as "momentary switch". The function output should only be ON while the corresponding function key is pressed. Alternatively - if supported by your decoder - you may program the output as time-limited (the output goes on when you press the function key and stays on for a short pre-determined time).

5.3. Operation with ZIMO Decoders (MX634 and similar)

The uncoupling function of ZIMO decoders is perfectly suited for the kit. Attach the couplers to one of the function outputs FO1...FO6 as desired (serial configuration = both couplers on one output recommended).

CV	Value	Meaning
#128...#132 (FO1...FO6, pick desired)	48	Uncoupler function on this output

CV	Value	Meaning
#115	46	Tens digit: full power time ("4" = 0.8s) Ones digit: hold power in 10% percent ("6" = 60%)
#116	173	Hundreds digit: Back up to unload coupler before decoupling ("1") Tens digit: Back-away (disengage) time ("7" = 3 seconds) Ones digit: Internal speed while backing away ("3" = speed 12)

5.4. Operation with ESU Lokpilot 4.0

ESU Lokpilot's 4.0 "digital coupler" differs from the above sequence because it opens the knuckle *before* the locomotive backs up, causing the knuckle to jam to the wagon's one, thus hindering proper uncoupling.

To work around this, we must use the "digital coupler" function only for the back-and-forward movement and map the function output to "virtual", non-existent AUX output (e.g. AUX10). The actuator itself will be connected to AUX1, which will be linked to AUX10 "digital coupler" function via ESU's function mapping.

AUX1 must be mapped to the same function key as the uncoupler function (here: F1), but with additional switch-switch-on delay and automatic switch off. The switch-on delay must be set accordingly so the couplers open just when the locomotive reverses direction, while the automatic switch-off must be set to hold the coupler open long enough (but no longer).

In the example mapping below, the automatic decoupling function is invoked by the function key F1.

Options controlling automatic back and forth movement

CV#2	CV	Value	Meaning
0	#347	28	AUX10 Mode Select = Digital uncoupler
0	#246	1	Speed during automatic uncoupling
0	#247	255	Time of backing away from the train (after decoupling) in 0.016s = 4.1s
0	#248*	95...105	Time of backing up to the train (before decoupling) in 0.016s = 1.55 ... 1.72s

Options controlling the coupler output (connected AUX1)

CV#2	CV	Value	Meaning
0	#275	1	AUX1 Mode Select = "Dimmable light"
0	#276*	6	Switch-on delay in 0.4s steps (2.4s)
0	#277	3 (max 12)	Switch-off delay in 0.4s steps (1.2s). Keep as short as possible for optimal operation, must never exceed 5 seconds!
0	#278	31	Maximum switch-on time = 100%

Conditions to trigger AUX1 together with "digital coupler" function on AUX10

NOTE: To access these values, set CV 32 = 2 before!

CV#2	CV	Value	Meaning
2	#353,#369	64	Mapping rows 7/8 (AUX1), Control CV A: Condition "F1=An"
2	#354 to #361, #370 to #377	0	Mapping rows 7/8 (AUX1), Control CV B ... I: no conditions
2	#362,#378	4	Mapping rows 7/8 (AUX1), Control CV K: Switch on AUX1
2	#363,#379	8	Mapping rows 7/8 (AUX1), Control CV L: Switch on AUX10



The most critical values are CV #276 (coupler turn-on delay) and CV #248 (back-up time). These values must be tuned to each other; play around with them until you find the optimal combination. This is around the point where the coupler opens just when the loco is just stopping. In general, CV #276 must increase when CV #248 increases and vice versa.

- If the coupler opens too early (while the loco is still backing up), increase CV #276.
- If the coupler opens too late (while the loco is backing away), decrease CV #276.

6. SPECIFICATIONS

Parameter	Value
Coupler operating voltage	12-18 VDC (when using the supplied 100 ohms resistors).
Coupler operating current	150 mA
Maximum "ON" time	5..10 seconds; a 20 second pause before the next decoupling cycle is required
Dimensions	5/64" dia x 15/32" length / 6 x 12mm

7. TROUBLESHOOTING

Although the knuckle is actuated, decoupling fails.

- The couplers are not fully pushed in: If there is any slack between them, the opening knuckle jolts on the mating coupler's one and fails to slide out of way.
→ *Always make sure that the couplers are fully pushed together before uncoupling.*
- The thread does not run in parallel to the shank. This causes the coupler to swing to the side *before* the knuckle is opened and may hinder the proper opening of the knuckle.
→ *Make sure that the thread pulling the actuator runs absolutely parallel with respect to the shank.*
- The thread and/or the reel cannot move freely, they have too much friction.
→ *Make sure that the thread can run freely, the actuator's reel does not have contact to a fixed part, and that the thread has not slipped into the gap between the reel and the actuators axis.*
- Automatic decoupler timing is not correct.
→ *Adjust the timing according to chapter 5. Programming the Decoder*
- Decoupling fails when only one or two (light) cars are attached
→ *Lower the series resistor by paralleling two 100 ohm resistors to achieve a "kick-off" effect (only recommended when decoder supports automatic uncoupling).*

8. APPENDIX

8.1. Warranty

We offer a full two (2) year warranty from the date of purchase. Within this period, we repair or exchange your device free of charge in case of any defect*. If you experience any problems, please contact us first. We try hard to solve your problem as soon as possible, even after the warranty period.

* Not covered by the warranty are any damages resulting out of improper use, willful damage, and especially overheating due to operation outside the specifications.

8.2. Contact

Precimodels	www.precimodels.com
Rolf Eichenseher	info@precimodels.com
Bullingerstr. 63 / BK241	Phone: +41 43 537 28 51
CH-8004 Zürich	Mobile: +41 76 747 07 42
Switzerland	

8.3. About this document

All trademarks mentioned in this document are property of the respective owners.

All information provided here is subject to change without prior notice.

Document Revision: 1 · 2020-09-21

Copyright © 2014-2020 Precimodels · Printed in Switzerland